

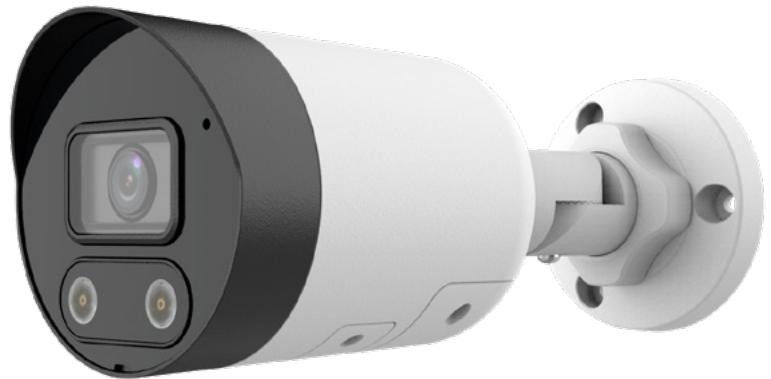

VIGILANT FLEX SERIES



Meets federal government technical requirements

ALIBI VIGILANT PERFORMANCE SERIES 4MP STARLIGHT SMARTSENSE IP FIXED BULLET CAMERA WITH WHITE LIGHT STROBES AND AUDIBLE ALARM

Key Specifications:

- + 4MP IP fixed bullet camera
- + 2.8mm lens with 101 degrees FOV
- + Smart Intrusion Prevention analytics
- + Strobe and audible alarm sound when triggered
- + Starlight chipset (.003 lux) for color in low light conditions
- + 98 feet Smart IR Distance
- + Built-in mic and speaker
- + Wide Dynamic Range (WDR)
- + 3D Digital Noise Reduction (DNR)
- + MicroSD card slot - up to 256GB
- + IP67 weather resistant rating
- + NDA A compliant

What's Included

- + 4MP IP fixed bullet security camera
- + Mounting template
- + Mounting hardware
- + Quick start guide

As part of the Alibi Vigilant Performance Series, this IP fixed bullet camera delivers crisp video day or night and has been designed and manufactured to comply with the latest technical requirements specified under NDA A regulations.

- + **Multi-Megapixel Resolution Video** - 4MP resolution allows you to capture a high level of clarity and detail for most applications.
- + **3D Digital Noise Reduction (DNR)** effectively filters noise to produce a crisper, clear video stream.
- + **Advanced Analytics with Strobe and Audible Alarm** - SmartSense analytics deliver AI powered event detection for vehicle and human detection that can activate the built-in white light strobes and a high decibel alarm when triggered.
- + **Full Frame Illumination with Smart IR** - Smart full-frame illumination technology offers several advantages over standard IR for flawless night vision, including: Clearer, brighter images in low light and at night; Delivers a wider illumination spread; Unique rectangular IR LED design produces a uniformly illuminated image across the entire screen; Reduces overexposure at the center of the image and eliminates hot spots; Eliminates blooming from lights by reducing ambient light pollution; Reduces video noise for a clearer nighttime picture, and reduces bandwidth consumption and video storage requirements
- + **Innovative Day/Night Scene Detection** - includes a hardware sensor for smart software imaging that detects surveillance scene illumination. Designed to be water and dust-proof, this allows you to avoid unexpected costs of hardware failure.
- + **Ultra H.265 Compression** - reduce bandwidth and storage requirements. With Ultra H.265 compression technology, you can store more information using less hard drive space. Ultra H.265 also helps you minimize bandwidth requirements for high-resolution video and makes the remote viewing less demanding on the recorder.
- + **IP67 weatherproof housing** - this camera can handle long-term durability even among extreme weather conditions such as rain, snow, and ice.
- + **Intuitive interface** - everything you need to manage your system at your fingertips. With an intuitive interface and access to the free Alibi CMS and mobile app, system management has never been simpler.



Precision Security Specialist

3306070265

<http://PSS.alibidealer.com>

SPECIFICATIONS

CAMERA

Sensor	1/2.7", 4.0 megapixel, progressive scan, CMOS
Lens	2.8mm@F1.6
DORI Distance	Lens (mm): 2.8 Detect (m): 63 Observe (m): 25.2 Recognize (m): 12.6 Identify (m): 6.3
Angle of View (H)	101.1°
Angle of View (V)	55.3°
Angle of View (O)	111.1°
Adjustment angle	Pan: 0° - 360°; Tilt: 0° - 90°; Rotate: 0° - 360°
Shutter	Auto/Manual, 1 - 1/100000s
Minimum Illumination	Colour: 0.003Lux (F1.6, AGC ON) 0Lux with Light on
Digital noise reduction	2D/3D DNR
Day/Night	IR-cut filter with auto switch (ICR)
S/N	>56dB
IR Range	Up to 30m (98 ft) IR range
Wavelength	850nm
IR On/Off Control	Auto/Manual
Defog	Digital Defog
WDR	120dB

VIDEO

Video Compression	Ultra 265, H.265, H.264, MJPEG
H.264 code profile	Baseline profile, Main profile, High profile
Frame Rate	Main Stream: 4MP (2688*1520), Max 30fps; 4MP (2560*1440), Max 30fps; 3MP (2304*1296), Max 30fps; 1080P (1920*1080), Max 30fps; Sub Stream: 720P (1280*720), Max 30fps; D1 (720*576), Max 30fps; 640*360, Max 30fps; 2CIF(704*288), Max 30fps; CIF(352*288), Max 30fps; Third Stream: D1 (720*576), Max 30fps; 640*360, Max 30fps; 2CIF(704*288), Max 30fps; CIF(352*288), Max 30fps;
9:16 Corridor Mode	Supported
Video Bit Rate	128 Kbps-16 Mbps
OSD	Up to 8 OSDs
Privacy Mask	Up to 4 areas
ROI	Up to 8 areas
Motion Detection	Up to 4 areas

IMAGE

White Balance	Auto/Outdoor/Fine Tune/Sodium Lamp/Locked/Auto2
Digital Noise Reduction	2D/3D DNR
Smart IR	Support
Flip	Normal/Vertical/Horizontal/180°/90° Clockwise/90°Anti-clockwise
Dewarping	N/A
HLC	Supported
BLC	Supported

AUDIO

Audio Compression	G.711
Two-way audio	Supported
Suppression	Supported
Sampling Rate	8KHZ

STORAGE

Edge Storage	Micro SD, up to 256GB
Network Storage	ANR

INTELLIGENT

Smart intrusion Prevention	Cross line, intrusion, enter area, leave area detection;
Face capture	Support

SMART

Basic Detection	Motion detection, tampering alarm, audio detection
General Function	Watermark, IP address filtering, tampering alarm, access policy, ARP protection, RTSP authentication, user authentication

NETWORK

Protocols	IPv4, IGMP, ICMP, ARP, TCP, UDP, DHCP, RTP, RTSP, RTCP, DNS, DDNS, NTP, FTP, UPnP, HTTP, SNMP, HTTPS, SMTP, SSL
Compatible Integration	ONVIF (Profile S, Profile G, Profile T), API
Client	Alibi Vigilant CMS Alibi Vigilant Toolbox Alibi Vigilant Mobile
Web Browser	Plug-in required live view: IE9+, Chrome 41 and below, Firefox 52 and below Plug-in free live view: Chrome 57.0+, Firefox 58.0+, Edge 16+



Precision Security Specialist

3306070265

<http://PSS.alibidealer.com>

SPECIFICATIONS

INTERFACE

Network	1 RJ45 10M/100M Base-TX Ethernet
Built-in Mic	Supported
Built-in Speaker	Supported
Alarm Light	Supported

CERTIFICATIONS

Certifications	CE: EN 60950-1 UL: UL60950-1 FCC: FCC Part 15
----------------	--

GENERAL

Power	DC 12V±25%, PoE (IEEE 802.3af) Power consumption: Max 11.5W
Dimensions (L × W × H)	191 × 75 × 74mm (7.5" × 3.0" × 2.9")
Net Weight	0.50kg (1.10lb)
Material	Metal
Working Environment	-30°C - 60°C (-22°F - 140°F), Humidity: ≤95% RH (non-condensing)
Storage Environment	-30°C - 60°C (-22°F - 140°F), Humidity: ≤95% RH (non-condensing)
Surge Protection	4KV
Ingress Protection	IP67
Reset Button	Supported

DIMENSIONS

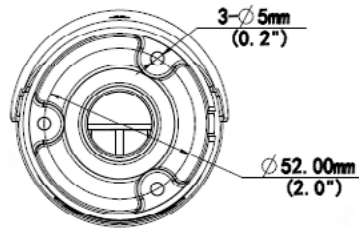
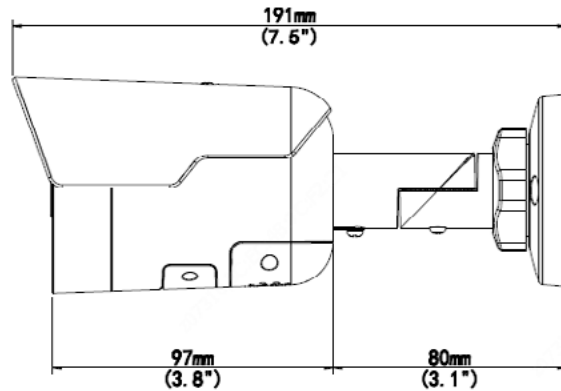
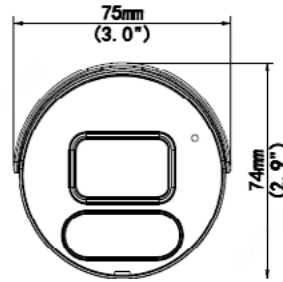

COMPATIBLE BRACKETS



Junction Box Waterproof Joint



Junction Box



Electric-box Transfer Plate for Fixed Lens Camera



Pole Mount Adapter for Bullet Cameras

Smart Analytics Supported:

- + Motion Detection
- + Tampering
- + Audio Detection
- + Intrusion Detection
- + Cross Line Detection
- + Enter Area
- + Leave Area
- + Face Detection
- + People Counting (People Flow Counting & Crowd Density Monitoring)



Precision Security Specialist

3306070265

<http://PSS.alibidealer.com>